

*accurate dosing*

# BELDOS

FOR A BETTER FILLING

*18 months warranty*

## Beltop Depositor

Compact and powerful!

Beldos offers a range of versatile volumetric stainless steel depositors with optional attachments for depositing, injection, layering and decoration. Beldos depositors will replace your pastry bag, spoon or a measuring cup and will become the most reliable, easy-to-use and intelligent equipment at your production!

1. The Beltop depositor is available in two series:

- 275 – 5-275 ml per deposit
- 670 – 5-670 ml per deposit

2. Design features:

- mounted on height adjustable feet
- hoppers: 18 l / 25 l
- 2 operation modes:
  - foot pedal
  - handgun switch



*everyone can work with it*

*100% hygiene control*



CLICK HERE TO WATCH THE MOVIE

*low investment*

*up to 120 deposits/min*

# SPECIFICATIONS

	Beltop 275	Beltop 670
POWER	Air: 29 l/min at 30 deposits/min, 7 Bar/102 PSI	Air: 121 l/min at 30 deposits/min, 7 Bar/102 PSI
DEPOSIT RANGE	5-275 ml	5-670 ml



deposit speed:  
up to 120  
deposits/min



particle size:  
max Ø 2,5 cm



stainless steel

*fast, accurate,  
clean & easy dosing*

*quick  
cleaning*

18 l / 25 l  
conical or vertical  
hoppers



product cylinder

DEPOSIT VOLUME PER SERIES			
Cylinder size mm	min volume	series 275	series 670
		max volume	
28	5	40	60
40	10	86	140
52	30	151	240
70	100	275	430
85	200	-	670

*more than 60  
nozzles available*

*tool-free  
assembly*



rotation cylinder



MEDIUM t°	0° - 60° C
COLD t°	-8° - 0° C
HOT t°	above 60° C



adjust the volume

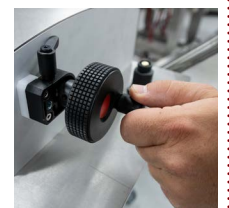

adjust the speed



height adjustable feet



# OPTIONS

## HOPPERS & ATTACHMENTS



heater jacket



conical hoppers  
18 l / 25 l

for depositing pourable  
products



vertical hopper  
25 l

for depositing heavy  
or aerated products



heater jacket



follower plate  
synthetic



cooling jacket



hopper division



follower plate  
st. steel

*multi-functional*

## NOZZLES & ATTACHMENTS

*various options  
for different  
viscosities*



nozzle 90°



handgun  
nozzle



horizontal  
nozzle



rotary cut-off  
nozzle



double nozzle  
injection



vertical  
nozzle



diving nozzle  
ECONO



diving  
nozzle



sheet icing  
nozzle



spreader &  
icing  
attachment

SEE A COMPLETE OVERVIEW OF THE OPTIONS IN THE PRICELIST



 - 8°  
cold products

# APPLICATIONS

sweet & savoury  
products

+120°   
hot products



## DEPOSITING

depositing of cake batter, muffins, jam, jelly, fruit filling, cream, mousse, meringue, ice-cream, yoghurt, soup, sauce, mashed potatoes, minced meat, salad, etc.



## INJECTION



injection of éclairs, Berliners, profiteroles



increased  
production  
efficiency

save ingredients  
by correct dosing

*compact  
&  
safe design*

## DIMENSIONS

### Beltop 275

*top quality  
equipment*

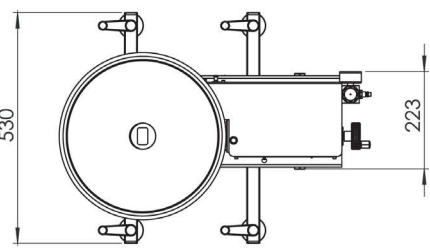
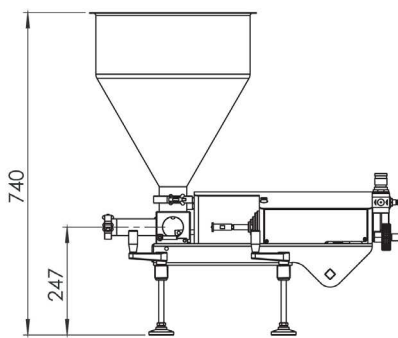
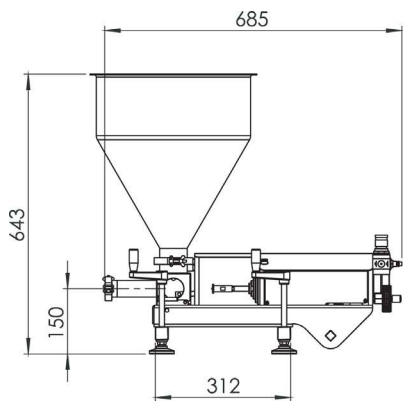

### Beltop 670

*easy to use  
&  
fast to clean*

*all stainless  
steel construction*

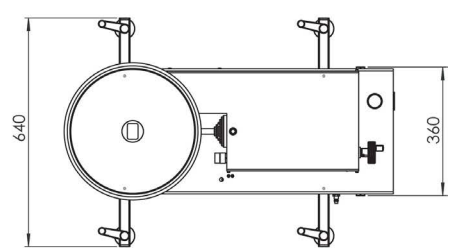
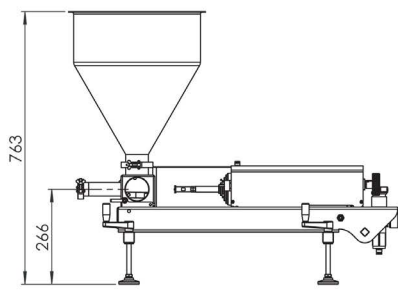
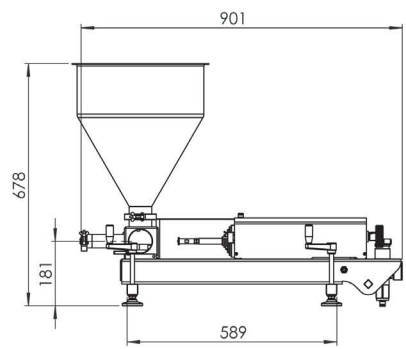

Beldos N.V.  
Industrielaan 10  
2950 Kapellen  
Antwerp province  
Belgium

+32 3 646 40 48  
info@beldos.be  
www.beldos.com

